

# Ezy-Drink<sup>®</sup> Lead Safe<sup>™</sup> Remote Electronic Drinking Bubbler Tap - Battery

PRODUCT CODES:

- 170.81.11.00

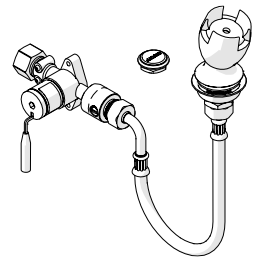

## SPECIFICATIONS

- Drinking taps are designed to operate at full mains pressure.
- The rubber mouthguard is resistant to fungal and bacterial attack and has a high resistance to sunlight.
- Adjustable built-in flow restrictor.

**IMPORTANT:** All Ezy-Drink<sup>®</sup> remote bubbler taps are tested in accordance with AS/NZS 3718 and leave our premises in good working order.

As 'lead free' is not currently defined by law in Australia and New Zealand, we have based our definition of Lead Safe<sup>™</sup> on the requirements of s1417 of the USA's Safe Drinking Water Act (SDWA) and the relevant US standards NSF61 / NSF372. The SDWA defines 'lead free' as "not more than a weighted average of 0.25% lead when used with respect to the wetted surface of pipes, pipe fittings, plumbing fittings and fixtures".

## TECHNICAL DATA

Inlet			½" BSP - Female	
Outlet			Rubber mouthguard	
Headwork			Piezo Activation	
Working Pressure Range (kPa)	Min	50		
	Max	500		
Working Temperature Range (°C)	Min	5		
	Max	60		
Nominal Flow Rate (LPM)			1.44	
Solenoid	Input Voltage		6 V DC	
	Power Consumption		-	
	Cable length		3.2m	
	Connection	Inlet	1/2" BSP - Female	
		Outlet	1/2" BSP - Male	
	Pressure Range (kPa)	Min	50	
		Max	500	
	Temperature (°C)	Min	5	
Max		60		
Finish			Chrome	

**NOTE:** Galvin Specialised continually strive to improve their products. Specifications may change without notice.

### TOOLS REQUIRED

- Power drill
- Spanner or adjustable crescent
- Screw driver

### PRE-INSTALLATION - MOUNTING DETAILS

**Controller programming is locked. If specific changes need to be made, contact Galvin Specialised.**

- If the mounting holes do not already exist, mark out and drill the holes in the bench/trough, as shown in rough-in dimensions.

*Note: Supplied flexi hose length is 225mm long. Maximum distance between the solenoid and outlet is 210mm.*

**Note: Before installation, all lines must be flushed.**

**We recommend that a line strainer be installed prior to drinking taps to eliminate any foreign material.**

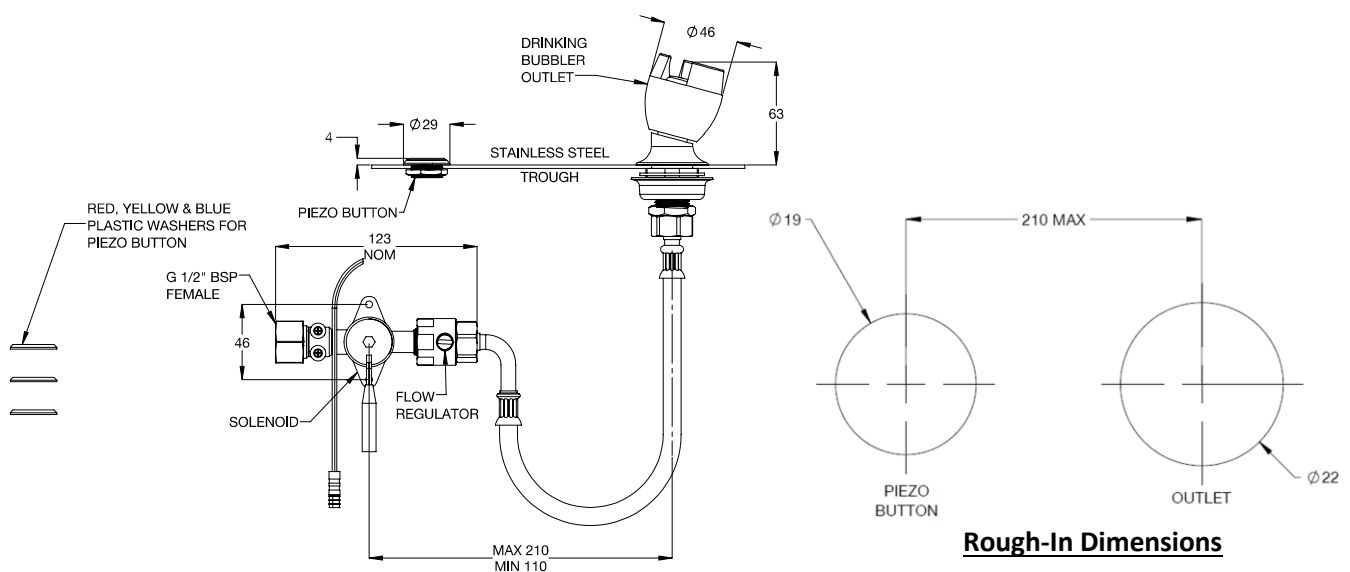

### INSTALLATION

**IMPORTANT:** Galvin Specialised products must be installed in accordance with these installation instructions and in accordance with AS/NZS 3500, the PCA and your local regulatory requirements. Water and/or electrical supply conditions must also comply to the applicable national and/or state standards. Failing to comply with these provisions shall void the product warranty and may affect the performance of the product.

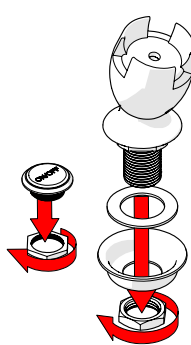

- 1. Disassemble piezo button and outlet**
  - Remove back nut and cup washer from the outlet assembly
  - Remove back nut from piezo button

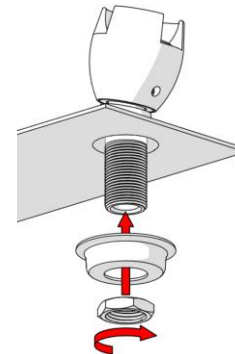

- 2. Fit mouthguard outlet**
  - Fit the mouthguard outlet into the trough.
  - Ensure the sealing rubber washers are placed underneath the mouthguard outlet body.
  - Secure underneath with the supplied cup washer and back nut.

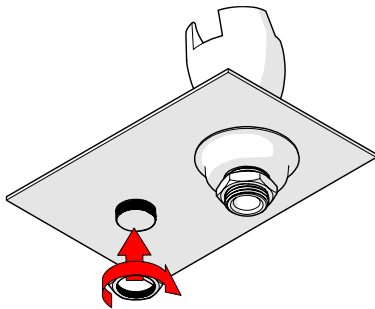

### 3. Fit Piezo Button

- Install piezo button and connect it to the electronic control unit.
- Ensure the correct coloured washer is fitted underneath the button.

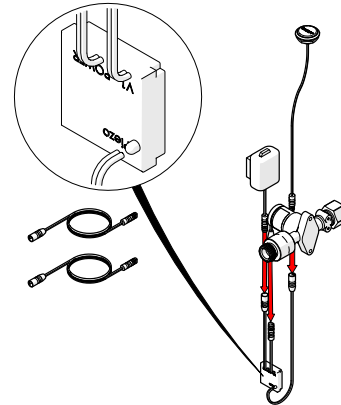

### 4. Connect Piezo button, Solenoid and Battery

- Connect Piezo button, the solenoid and the battery to the electronic control unit.
- The unit was supplied with 2 x 3.2metre extension leads for connecting to battery and solenoid.

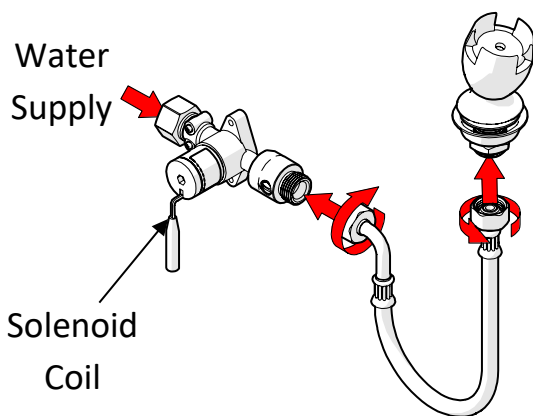

### 5. Fit Solenoid and Outlet

- Fix the solenoid in position ensuring that the solenoid coil is not facing downwards.
- Fit flexi hose to solenoid and water supply.
- Fit flexi hose to outlet

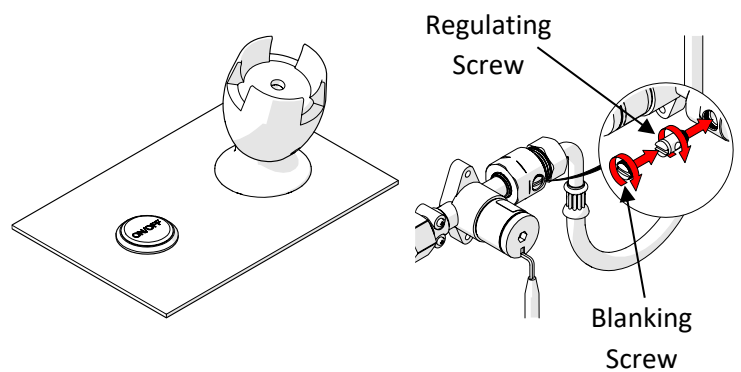

### 6. Testing

- Once the drinking tap has been installed and tested for leaks, the water height may be adjusted to suit the available pressure.
- To adjust water flow (if required)
  1. Remove the blanking screw
  2. Adjust the water flow by turning the regulating screw
  3. Replace blanking screw

**Note: The full range from minimum flow to maximum flow is only ¼ turn**

## SET WATER FLOW DURATION

Contact Galvin Specialised for information regarding changing flow duration.

TROUBLESHOOTING		
PROBLEM	CAUSE	RECTIFICATION
Water is not flowing from tap	Water is turned off	Turn on water
	Blocked flow regulating screw	Remove flow regulating screw and clean
Rate of flow inadequate	The flow regulator screw may not be adjusted correctly	Remove blanking screw and adjust flow regulating screw as described above

**WARRANTY**

The warranty set forth herein is given expressly and is the only warranty given by the Galvin Engineering Pty Ltd. With respect to the product, Galvin Engineering Pty Ltd makes no other warranties, express or implied. Galvin Engineering Pty. Ltd. hereby specifically disclaims all other warranties, express or implied, including but not limited to the implied warranties of merchantability and fitness for a particular purpose.

Galvin Engineering Pty Ltd products are covered under our manufacturer’s warranty available for download from [www.galvinengineering.com.au](http://www.galvinengineering.com.au) Galvin Engineering Pty Ltd expressly warrants that the product is free from operational defects in workmanship and materials for the warranty period as shown on the schedule in the manufacturer’s warranty. During the warranty period, Galvin Engineering will replace or repair any defective products manufactured by Galvin Engineering without charge, so long as the terms of the Manufacturer’s warranty are complied with.

The remedy described in the first paragraph of this warranty shall constitute the sole and exclusive remedy for breach of warranty, and Galvin Engineering Pty Ltd shall not be responsible for any incidental, special or consequential damages, including without limitation, lost profits or the cost of repairing or replacing other property which is damaged if this product does not work properly, other costs resulting from labour charges, delays, vandalism, negligence, fouling caused by foreign material, damage from adverse water conditions, chemical, electrical or any other circumstances over which Galvin Engineering has no control. This warranty shall be invalidated by any abuse, misuse, misapplication, improper installation or improper maintenance or alteration of the product.